

MODEL: SIGHT-LINE COMMAND CENTER CONSOLE

1 GENERAL DESCRIPTION

- 1.1 Sight-Line Command Center Consoles. See Appendix "A" - "C" for typical styles and measurements.
- 1.2 The contractor shall supply a system capable of supporting specified electronics.
- 1.3 The system shall be comprised of end frames and/or intermediate frames with horizontal stringers and decorative end panels. The system will also feature a hinged dual-channel duct cover with integrated aluminum Versa-Trak mounting system for LCD monitor arrays.
- 1.4 The system shall have a minimum 1-1/8" (29mm) thick industrial grade 45 lb. particle board core work surface with a protective rubber Safeguard T-edge. The work surface shall be 22-3/4" (578mm) deep overall and finished with a high pressure laminate on top and warp resistant backer on the bottom.

2 STANDARD

- 2.1 Optional 7" (4U), 10-1/2" (6U), and 19-1/4" (11U) rack mount turrets, and tapped rack rails for lower storage compartment shall comply with Electronic Industry Association (E.I.A.) specifications for rack mounting ANSI/E standard RS-310.
- 2.2 All monitor mounts used with the integrated Versa-Trak mounting system are compliant with the Mounting Interface Standard established by the Video Electronics Standards Association (VESA).

3 DRAWINGS

- 3.1 The contractor shall supply five sets of scaled drawings for each console assembly showing the location of all the specified electronics in isometric view in addition to a plan (top) and front views.
- 3.2 The specification of sizes and dimensions shown in the drawings shall have a tolerance of not more than +/- 0.062" (1.6mm).

4 MODULAR PRE-ENGINEERED CONSTRUCTION

All components within the system shall be:

- 4.1 Of a pre-engineered modular construction, i.e: constructed from a series of independent sectional compartments.
- 4.2 Available from a pre-defined set of manufacturers model numbers.
- 4.3 Free from alterations to the design either prior to or following installation. The assembly of the console shall be accomplished without the need for either welding or carpentry work.
- 4.4 Constructed of a steel super-structure framework consisting of intermediate and end frames connected by horizontal stringers. External decorative side panels are available in TruForm or laminated MDF core.

5 SELF SUPPORTING SKELETON FRAMEWORK

The self supporting skeleton framework shall:

- 5.1 Be installed at the site in advance of any external finishing panels. The framework shall be fully capable of supporting all specified electronics without the need for attachment of any external panels.
- 5.2 Be capable of being supplied to site in knockdown (flat packed) form and be capable of assembly using 10-32 bolts and Insta-Lock fastening system without welding or carpentry work.
- 5.3 Include front and rear horizontal stringers constructed of 12 gauge* (.104") formed sheet metal. Stringers will connect, and span, 14 gauge (.074") end frames and/or intermediate frames to form a complete structure.

6 COMPONENTS

6.1 INTERMEDIATE AND END FRAMES

14 gauge (.074") intermediate and end frames shall be a minimum of 1-1/2" (38mm) in width and capable of supporting fully loaded console. Intermediate and end frames shall incorporate 3/8" (10mm) diameter threaded adjustable glides and 2" (5mm) vertical slots for mounting two and four gang electrical boxes. End frames shall feature an anti-tip extension and the intermediate frames shall feature four grommet holes.

A&E SPECIFICATION

6.2 HORIZONTAL STRINGERS

12 gauge (.104") formed sheet metal horizontal stringers with Insta-Lock fastening system shall be 2" (51mm) high and available in 24" (609mm), 48" (1218mm), and 72" (1827mm) widths.

6.3 BOTTOM SHELF

16 gauge (.060") stationary steel shelf shall extend 17-5/8" (447mm) from the front of the console to the rear. Features four grommet holes and has a load capacity of 100 pounds, evenly distributed.

6.4 LOWER DOORS

Vented double-panel doors with off set face design and spring hinges for easy removal without the use of tools. Doors shall be supplied with a keyed-alike locking lever latch and integrated cable management. Doors shall be able to accept an optional CPU shelf or file/storage bin for convenient swing-out access.

6.5 CORNERS

15, 45, and 90 degree 12 gauge (.104") steel corner fillers shall be available. Corners fillers will feature Insta-Lock fastening system for ease of installation. Corners shall be available in concave and convex configurations.

6.6 DUCT COVER

18 gauge (.047") steel hinged duct cover conceals, and allows easy access to, dual cable raceway so signal and power cords can be separated.

6.7 DATA/POWER RAIL

14 gauge (.074") angled data/power rail shall include cable grommets and openings for a universal data mounting plate and openings for duplex power box. The data/power rail shall incorporate Insta-Lock fastening system and, combined with 14 gauge (.074") shelf brackets, will support the work surface.

6.8 VERSA-TRAK / MONITOR ARRAYS

Fully integrated black anodized aluminum track system capable of supporting a wide variety of monitor arrays while providing simple horizontal adjustment. Constructed of extruded 6105-T5 aluminum with a T-slot profile. Monitor array support posts shall be available in 15" (381mm), 28-1/2" (723mm), and 42" (1066mm) heights. The support posts shall be 1.9" (48mm) or 1.5" (38mm) in diameter with a wall thickness of .110" (2.8mm). Monitor arrays shall be mounted to the Versa-Trak with ball spring drop-in T-nuts.

6.9 LIFT-OFF BACK PANEL

16 gauge (0.60") vented lift-off back panel with integrated latch shall be available as an alternative to the lower doors.

7 FINISH AND COLOR

7.1 All exterior and frame steel components including doors, rack turrets, duct covers, and shelving shall be zinc oxide wash primer with a black powder coat textured finish.

8 OPTIONAL ACCESSORIES

8.1 A full range of optional accessories shall be available such as fans, electrical boxes, CPU shelves, file bins, rack mount turrets, monitor mounts, and LED task lighting with VESA mount or magnetic base.

9 MOUNTING HARDWARE

9.1 Mounting hardware for the specified electronics shall be available upon request. All hardware needed for assembly will be provided.

10 INSTRUCTIONS

10.1 Fully detailed assembly instructions in the English language shall be supplied with both written and pictorial descriptions for each item/model numbered component.

11 PACKAGING

11.1 Each component part number shall be independently marked and packed into double or triple ply corrugated outer cartons and shall be suitable for storage and shipping to site without damage.

12 WARRANTY

- 12.1 • A LIFETIME WARRANTY on all fixed steel structure frame components.
- A 10 year warranty on adjustable, sliding or hinged components and laminated surfaces.
- A 5 year warranty on Endurance Plus and TruForm surfaces.
- A 2 year warranty on all electrical components and chairs.

*American Standard Wire Gauge (ASWG).

A&E SPECIFICATION

FRONT VIEW

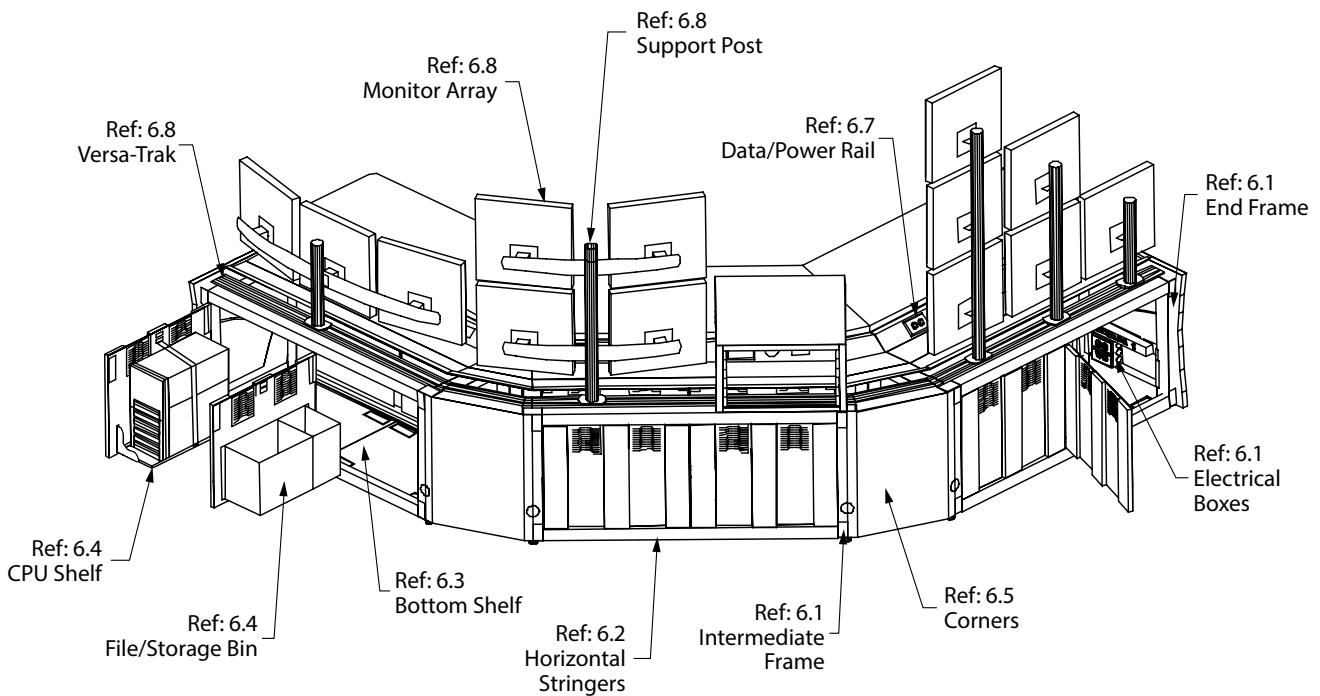
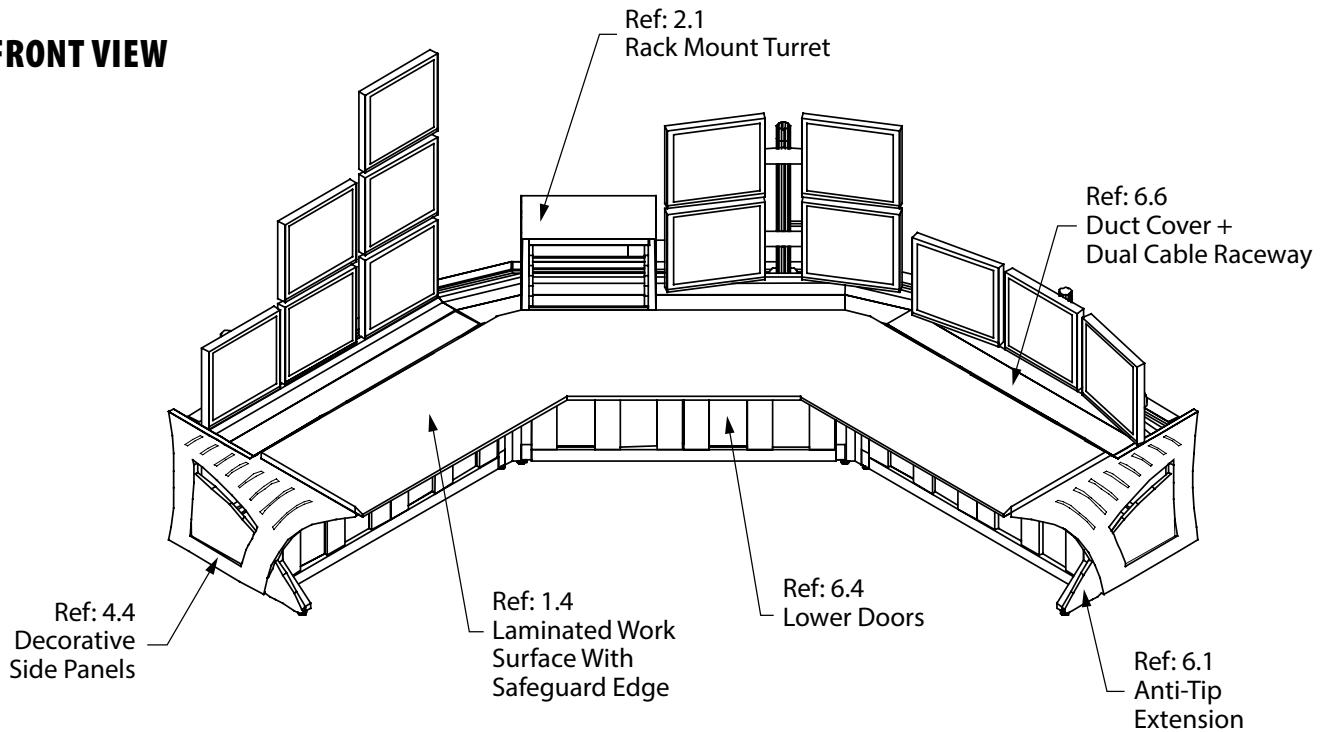

BACK VIEW

Section: A4

APPENDIX A

WINSTED CORPORATION GENERAL A&E SPECIFICATIONS

Page: 3

A&E SPECIFICATION

SINGLE
24" CHASE W/FRAMES

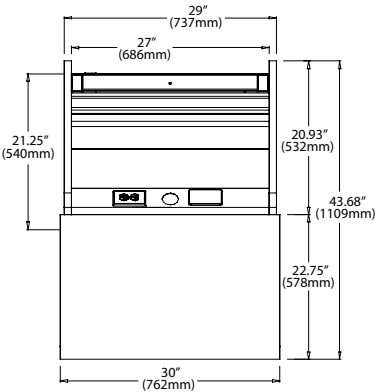

DOUBLE
48" CHASE W/FRAMES

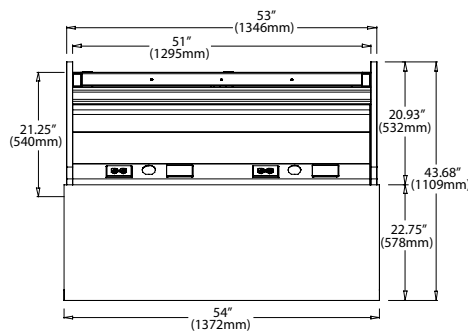

TRIPLE
72" CHASE W/FRAMES

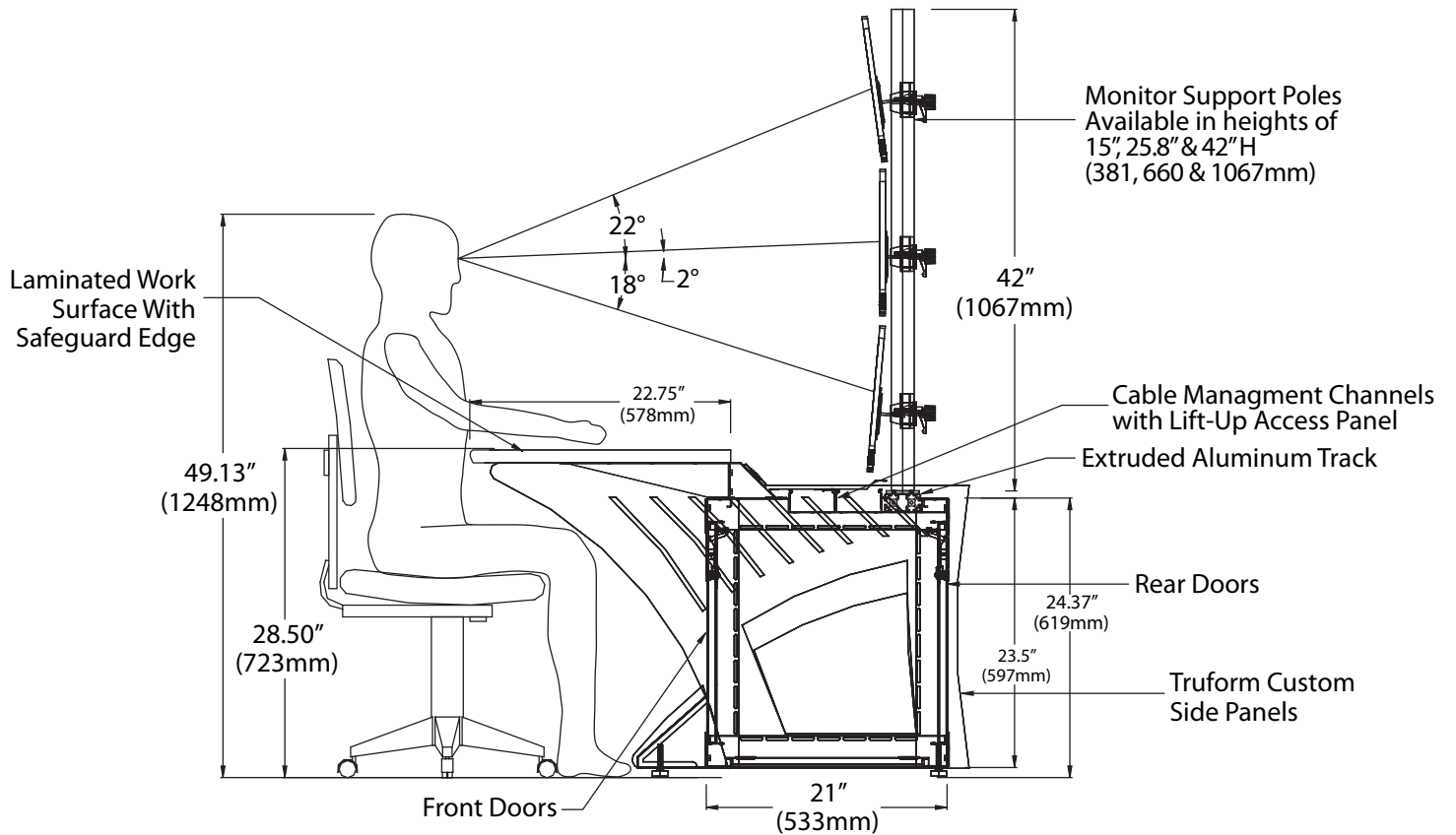
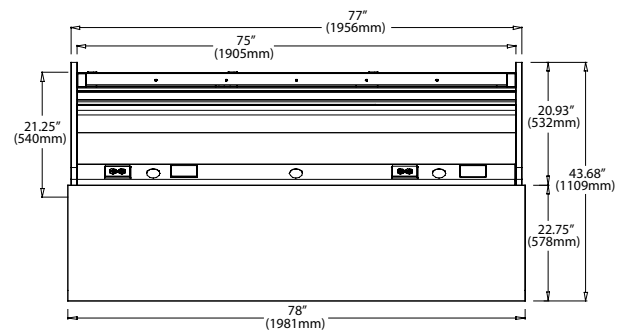

APPENDIX B

A&E SPECIFICATION

CORNERS REF: 6.5

15 DEGREE

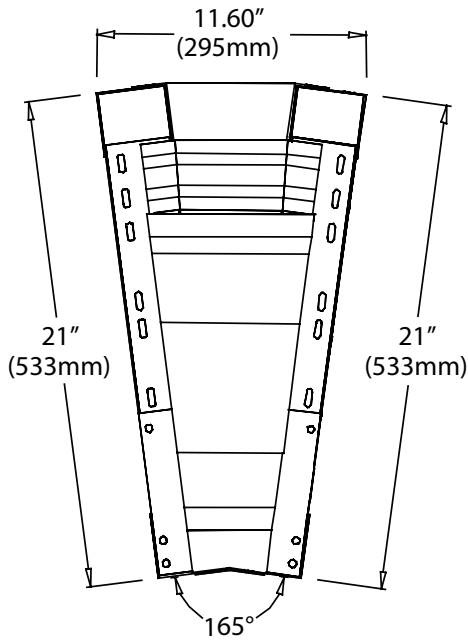

45 DEGREE

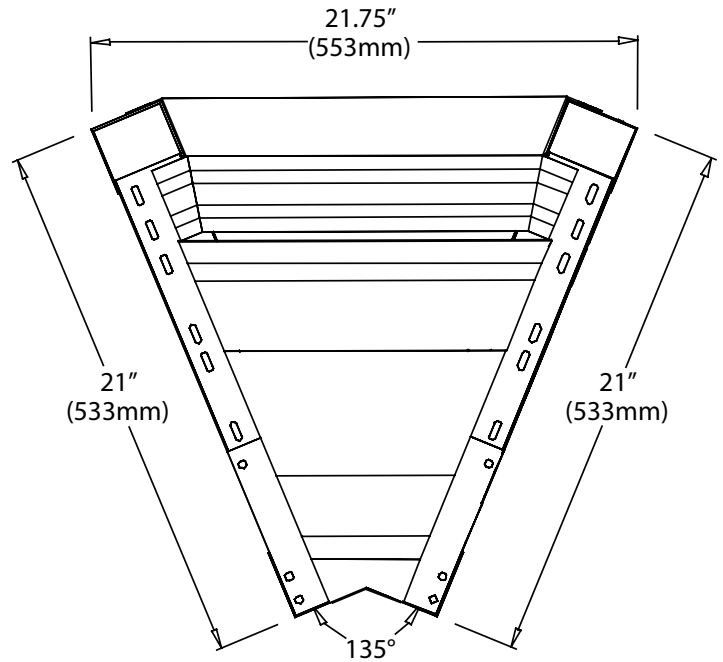

90 DEGREE

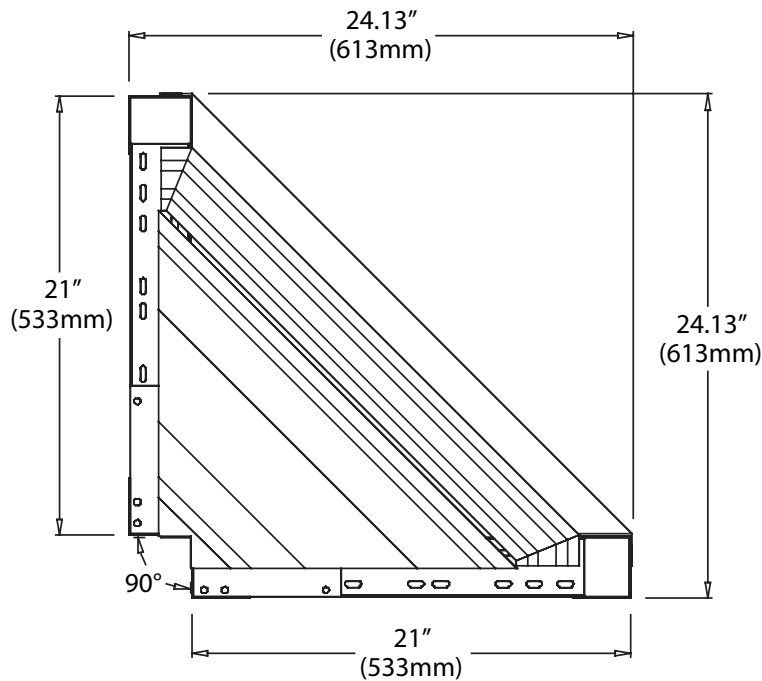

APPENDIX C