

## MODEL: IMPULSE - SINGLE SURFACE SIT/STAND CONSOLE

### 1 GENERAL DESCRIPTION

- 1.1 Impulse Single-Surface Sit/Stand Consoles. See Appendix "A" - "D" for typical styles and measurements.
- 1.2 The contractor shall supply a system capable of supporting specified electronics.
- 1.3 The console shall be comprised of end frames with dual electric-lift legs. The system will also feature an ergonomically height-adjustable work surface with an integrated aluminum Versa-Trak monitor mounting system.
- 1.4 The system shall feature a Graphite Nebula 1-1/8" (29mm) thick industrial grade 45 lb. particle board core work surface with a protective rubber Safe guard T-edge. The work surface shall be 42" (1067mm) deep overall and finished with a high pressure laminate on top and warp resistant backer on the bottom.

### 2 STANDARDS

- 2.1 All optional racks integrated with the console shall comply with Electronic Industry Association (E.I.A.) specifications for rack mounting ANSI/E standard RS-310.
- 2.2 All monitor mounts used with the Versa-Trak mounting system are compliant with the Mounting Interface Standard established by the Video Electronics Standards Association (VESA).

### 3 DRAWINGS

- 3.1 The contractor shall supply five sets of scaled drawings for each console assembly showing the location of all the specified electronics in isometric view in addition to a plan (top) and front views.
- 3.2 The specification of sizes and dimensions shown in the drawings shall have a tolerance of not more than +/- 0.062" (1.6mm).

### 4 MODULAR PRE-ENGINEERED CONSTRUCTION

All components within the system shall be:

- 4.1 Of a pre-engineered modular construction, i.e: constructed from a series of independent sectional compartments.

- 4.2 Available from a pre-defined set of manufacturers model numbers.
- 4.3 Free from alterations to the design either prior to or following installation. The assembly of the console shall be accomplished without the need for either welding or carpentry work.
- 4.4 Constructed of a steel super-structure framework consisting of end frames connected by a sheet metal horizontal modesty panel. Optional external decorative side panels are available in TruForm or laminated MDF core.

### 5 SELF SUPPORTING SKELETON FRAMEWORK

The self supporting skeleton framework shall:

- 5.1 Be installed at the site in advance of any external finishing panels. The framework shall be fully capable of supporting all specified electronics without the need for attachment of any external panels.
- 5.2 Be capable of being supplied to site in knockdown (flat packed) form and be capable of assembly without welding or carpentry work.
- 5.3 Include rear horizontal modesty panel constructed of 11 gauge\* (.119") formed sheet metal. Modesty panel will connect and span 14 gauge (.074") end frames to form a complete structure.

### 6 COMPONENTS

#### 6.1 END FRAMES

14 gauge (.074") end frames shall be a minimum of 4-1/2" (114mm) in width, capable of integrating two sets of electric-lift legs along with one pair of cable followers. End frames will support a fully loaded console and incorporate 3/8" (10mm) diameter threaded adjustable glides and a duplex power outlet. Quick-release lift-off access panels will be located on the inside each end frame.

#### 6.2 HORIZONTAL MODESTY PANEL

16 gauge (.060") formed sheet metal modesty panel shall incorporate an easy-access cable raceway.

# A&E SPECIFICATION

## 6 COMPONENTS (CONT.)

### 6.3 WORK SURFACE

The system shall feature two Graphite Nebula 1-1/8" (29mm) thick industrial grade 45 lb. particle board core work surface with a protective rubber Safe guard T-edge. The work surface shall be 20" (508mm) deep overall and finished with a high pressure laminate on top and warp resistant backer on the bottom.

### 6.4 PERFORATED PRIVACY PANEL

The work surface shall feature a 12" high perforated black painted 16 guage (.060") steel privacy panel.

### 6.5 VERSA-TRAK / MONITOR ARRAYS

Console shall feature a fully integrated black anodized aluminum track system capable of supporting a wide variety of monitor arrays. The Versa-Trak will provide uninterrupted lateral adjustability of monitors. Constructed of extruded 6105-T5 aluminum with a T-slot profile. Monitor array support posts shall be available in 15" (381mm), 28-1/2" (723mm), and 42" (1066mm) heights. The support posts shall be 1.5" (38mm) in diameter with a wall thickness of .120" (2.9mm). Monitor arrays shall be mounted to the Versa-Trak with ball spring drop-in T-nuts or to the surface with supplied hardware.

### 6.6 ELECTRIC-LIFT LEGS

Console shall integrate two sets of stretcherless electric-lift legs with a load capacity of 1040 pounds. The electric lift legs shall provide quick & easy work surface adjustment from 30"- 46" high.

## 7 FINISH AND COLOR

7.1 All exterior and frame steel components including end frames, modesty panels, and optional CPU pedestal shall be zinc oxide wash primer with a black powder coat textured finish.

## 8 OPTIONAL ACCESSORIES

8.1 A full range of optional accessories shall be available such as outlets, electrical boxes, CPU pedestal, file cabinets, monitor mounts and LED task lighting with VESA mount or magnetic base.

## 9 MOUNTING HARDWARE

9.1 Mounting hardware for the specified electronics shall be available upon request. All hardware needed for assembly will be provided.

## 10 INSTRUCTIONS

10.1 Fully detailed assembly instructions in the English language shall be supplied with both written and pictorial descriptions for each item/model numbered component.

## 11 PACKAGING

11.1 Each component part number shall be independently marked and packed into double or triple ply corrugated outer cartons and shall be suitable for storage and shipping to site without damage.

## 12 WARRANTY

### 12.1

- A LIFETIME WARRANTY on all fixed steel structure frame components.
- A 10 year warranty on adjustable, sliding or hinged components and laminated surfaces.
- A 5 year warranty on Endurance Plus and TruForm surfaces.
- A 2 year warranty on all electrical components and chairs.

\*American Standard Wire Gauge (ASWG).

# A&E SPECIFICATION

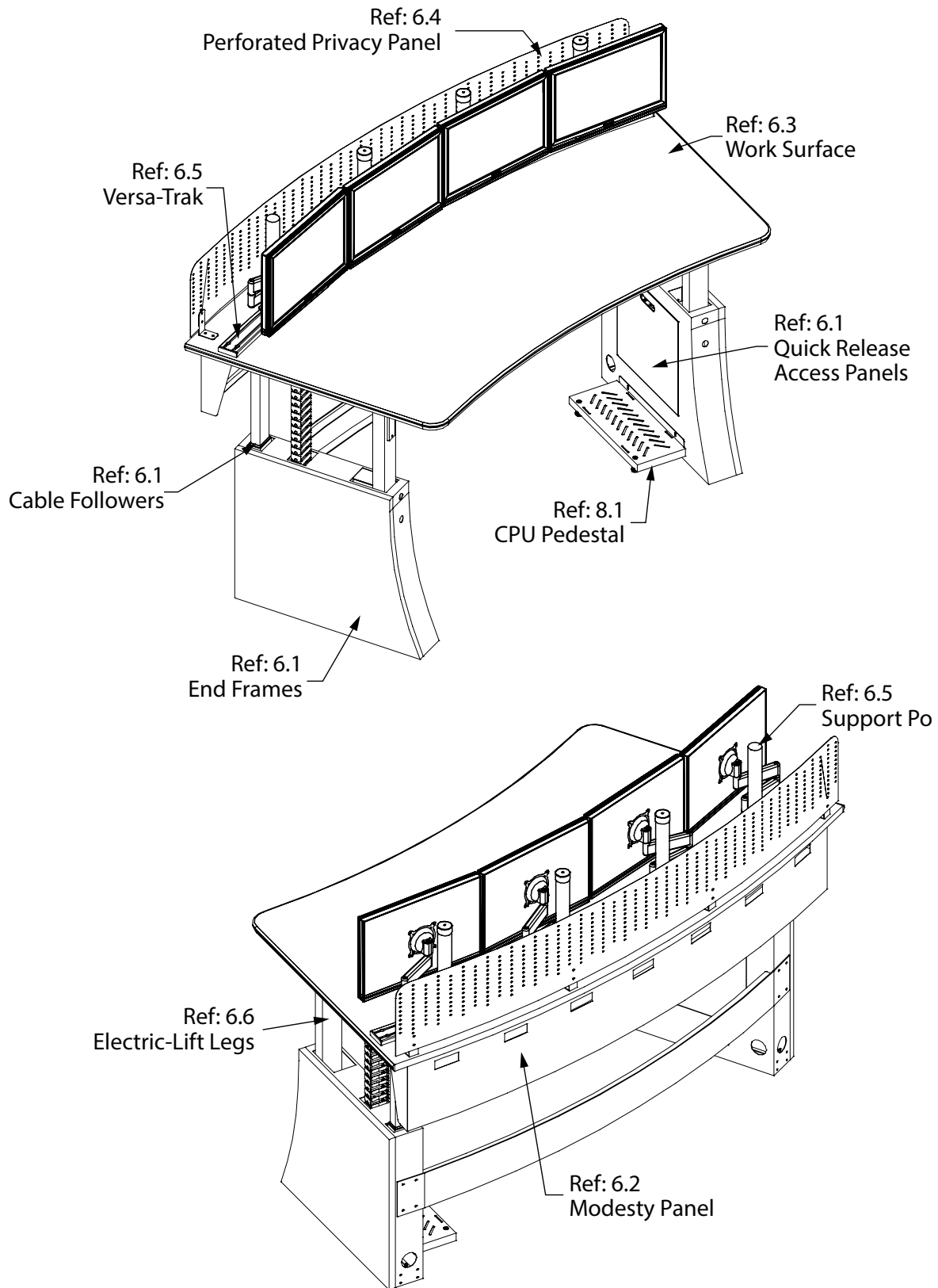

# A&E SPECIFICATION

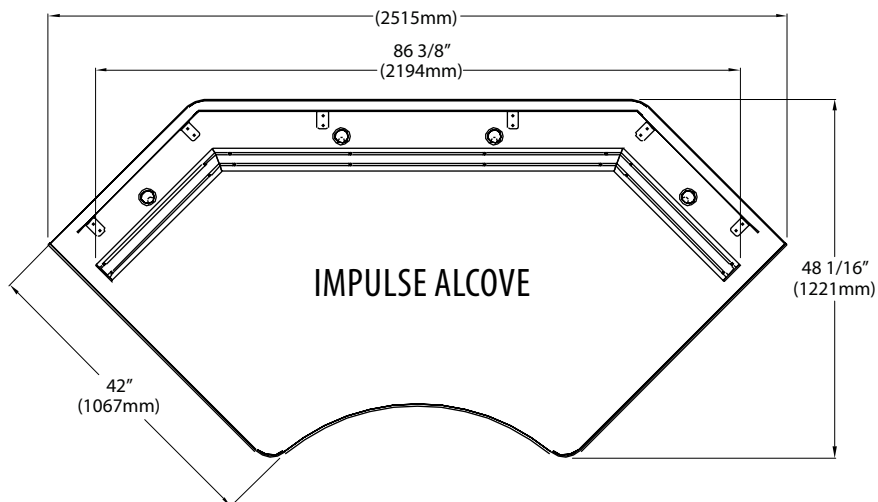
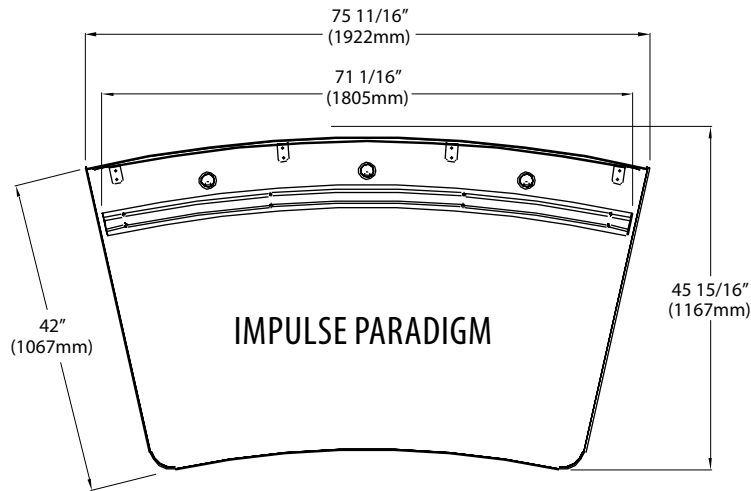
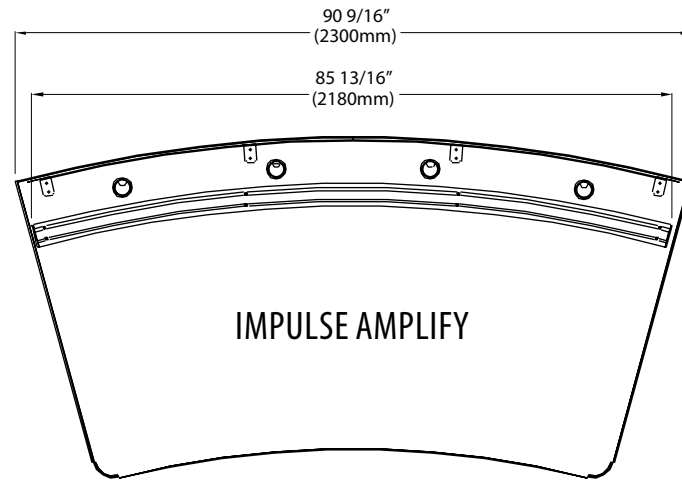

# A&E SPECIFICATION

---

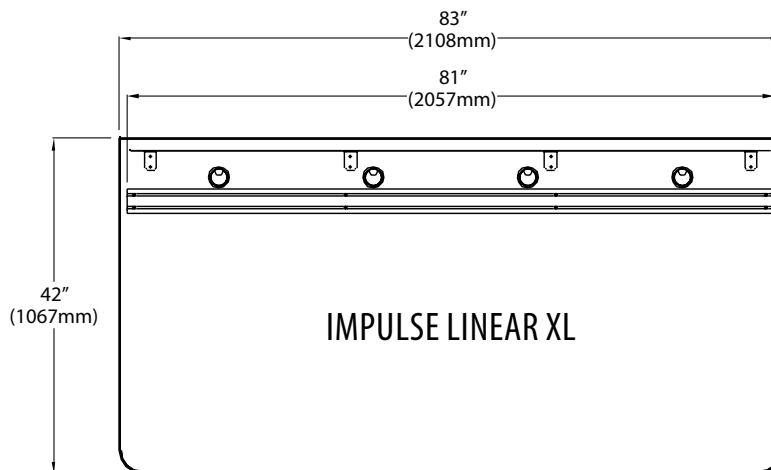
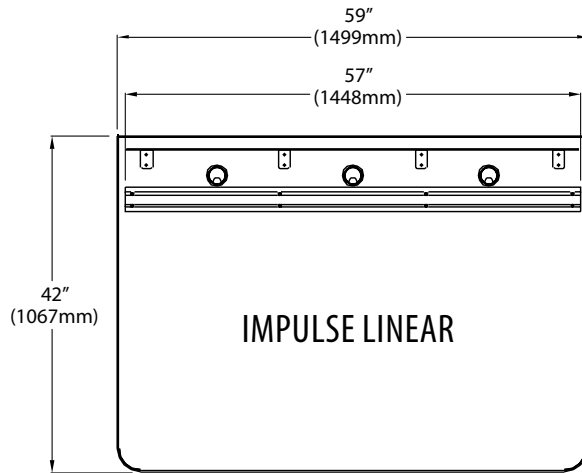

## ERGONOMIC DETAIL

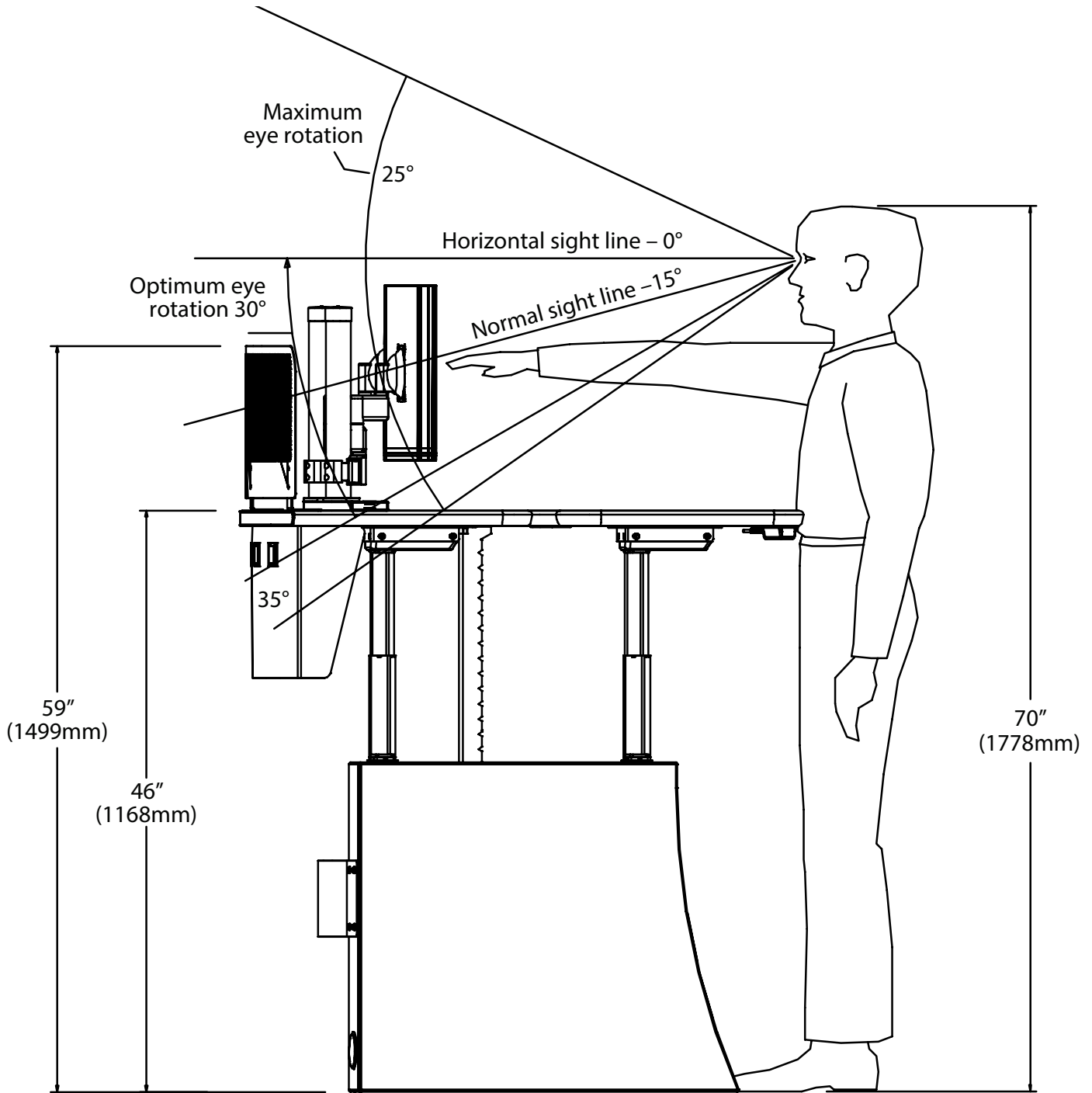

# A&E SPECIFICATION

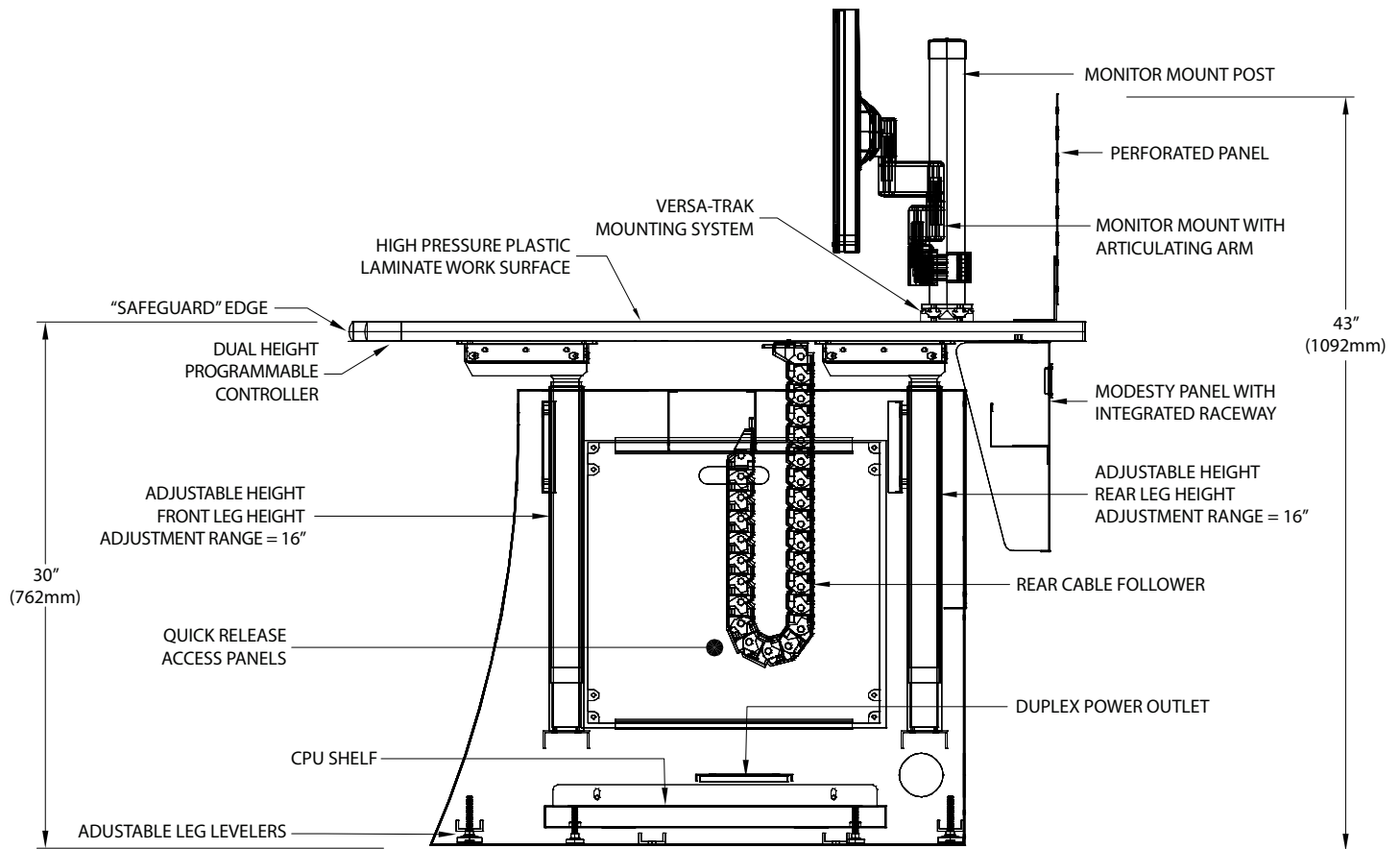

## GENERAL SPECIFICATIONS FOR ELECTRIC LIFT LEGS - REF: 6.6

<b>Inner Columns:</b>	Steel
<b>Outer Columns:</b>	Steel
<b>Mounting Plates:</b>	14 Gauge Formed Steel
<b>Levelers:</b>	1-1/4" Dia. Black Plastic 2" Stem
<b>Adjustment Range:</b>	16"
<b>Standard and Minimum Start Height:</b>	(Knee Clear) 30"
<b>Maximum Recommended Double Column Lift Weight:</b>	520 Lbs.