

MODEL: ENVISION COMMAND CONSOLE

1 GENERAL DESCRIPTION

- 1.1 EnVision Command Consoles see Appendix "A,B,C and D" for typical styles and measurements.
- 1.2 The contractor shall supply a system capable of supporting specified electronics.
- 1.3 The system shall be comprised of vertical support legs with horizontal slat-wall and work surface support tray.
- 1.4 The system shall have a minimum 1-1/8" (29mm) thick industrial grade 45 lb. particle board core work surface with a protective rubber Safeguard T-edge. The work surface shall be 22-3/4" (578mm) deep overall and finished with a high pressure laminate on top and warp resistant backer on the bottom.

2) STANDARDS

- 2.1 Optional rack mount turret shall comply with Electronic Industry Association (E.I.A.) specifications for rack mounting ANSI/E standard RS-310.
- 2.2 All monitor mounts used with the integrated Versa-Trak mounting system are compliant with the Mounting Interface Standard established by the Video Electronics Standards Association (VESA).

3 DRAWINGS

- 3.1 The contractor shall supply five sets of scaled drawings for each console assembly showing the location of all the specified electronics in isometric view in addition to a plan (top) and front views.
- 3.2 The specification of sizes and dimensions shown in the drawings shall have a tolerance of not more than +/- 0.062" (1.6mm).

4 MODULAR PRE-ENGINEERED CONSTRUCTION

All components within the system shall be:

- 4.1 Of a pre-engineered modular construction, ie: constructed from a series of independent sectional compartments.

- 4.2 Available from a pre-defined set of manufacturers model numbers.
- 4.3 Free from alterations to the design either prior to or following installation, will be accomplished without the need for either welding or carpentry work.
- 4.4 Constructed of a steel super-structure framework consisting of vertical support legs with horizontal slat-wall and work surface support tray.

5 SELF SUPPORTING SKELETON FRAMEWORK

The self supporting skeleton framework shall:

- 5.1 Be installed at the site in advance of any external finishing panels. The framework shall be fully capable of supporting all specified electronics without the need for attachment of any external panels.
- 5.2 Be capable of being supplied to site in knockdown (flat packed) form and be capable of assembly without welding or carpentry work.
- 5.3 Include vertical support legs constructed of 16 gauge* (.060") formed sheet metal. Horizontal slat-wall sections and work surface support tray will connect and span support legs to form a complete structure.

6 COMPONENTS

6.1 VERTICAL SUPPORT LEGS

16 gauge (.060") vertical support legs shall be a minimum of 5" (127mm) in width and capable of supporting fully loaded console. Support legs shall feature a front and rear anti-tip extension, grommet holes, 2-1/2" (64mm) diameter glides and removable rear access panels for cable management.

6.2 WORK SURFACE SUPPORT TRAY

14 gauge (.074") metal horizontal support tray shall be 1-1/4" (32mm) high and available in 20-1/4" (514mm), 38-1/4" (972mm), and 62-1/4" (1581mm) widths.

6.3 CORNERS

Corner angles will not be predefined by standard corner sections. Corner angles will be defined by the work surface and can be custom configured as needed to fit the application.

A&E SPECIFICATION

6 COMPONENTS (CONT.)

6.4 LIFT-OFF CABLE TRAY

18 gauge (.048") 4" deep horizontal cable tray shall attach to the rear of the slat-wall, no tools required to mount. Cable tray shall feature integrated lacing loops for large cable bundles.

6.5 SLAT-WALL MOUNTING SYSTEM

Fully integrated clear anodized aluminum slat-wall capable of supporting a wide variety of monitor mounts and standard slat-wall accessories. The slat-wall shall be constructed of extruded 6105-T5 aluminum with a double-walled vertical column and mounting channels on the front and back of the wall. The slat wall shall consist of one or two 7-1/2" (191mm) high panels for an overall height of 7-1/2" (191mm) or 15" (381mm) and an overall depth of 1-3/16" (30mm). The channel openings shall be 1-1/2" (38mm) on center, 3/4" (19mm) wide, 7/16" (11mm) deep on the front and 1/4" (6mm) deep on the back. Slat-wall mounting brackets allow for vertical and horizontal adjustment.

7 FINISH AND COLOR

7.1 All exterior and frame steel components shall be clear anodized or zinc oxide wash primer with a black powder coat textured finish.

8 OPTIONAL ACCESSORIES

8.1 A full range of optional accessories shall be available such as phone trays, electrical outlets, CPU mounts, rack mount turrets, monitor mounts, and LED task lighting.

9 MOUNTING HARDWARE

9.1 Mounting hardware for the specified electronics shall be available upon request. All hardware needed for assembly will be provided.

10 INSTRUCTIONS

10.1 Fully detailed assembly instructions in the English language shall be supplied with both written and pictorial descriptions for each item/model numbered component.

11 PACKAGING

11.1 Each component part number shall be independently marked and packed into double or triple ply corrugated outer cartons and shall be suitable for storage and shipping to site without damage.

12 WARRANTY

12.1

- A LIFETIME WARRANTY on all fixed steel structure frame components.
- A 10 year warranty on adjustable, sliding or hinged components and laminated surfaces.
- A 5 year warranty on Endurance Plus and TruForm surfaces.
- A 2 year warranty on all electrical components and chairs.

*American Standard Wire Gauge (ASWG).

A&E SPECIFICATION

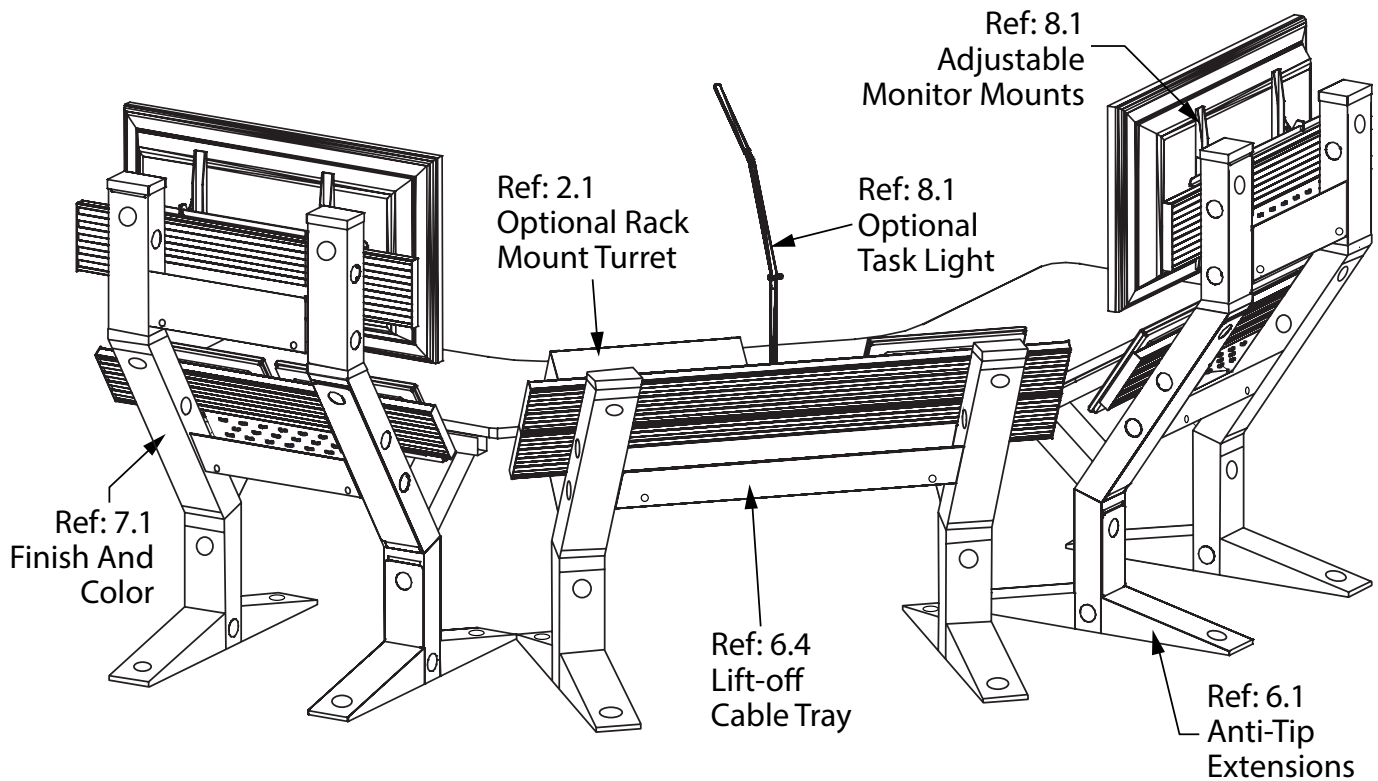
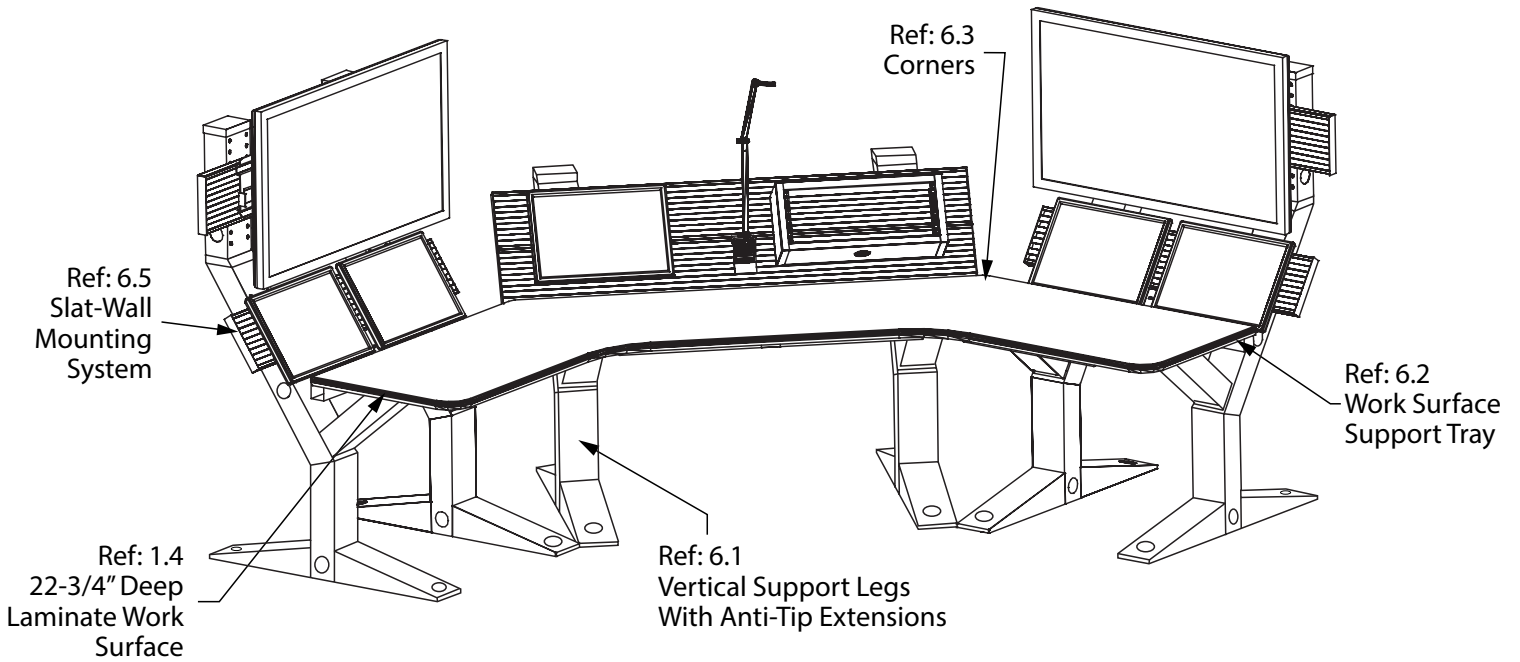

APPENDIX A

A&E SPECIFICATION

42" CHASE W/FRAMES

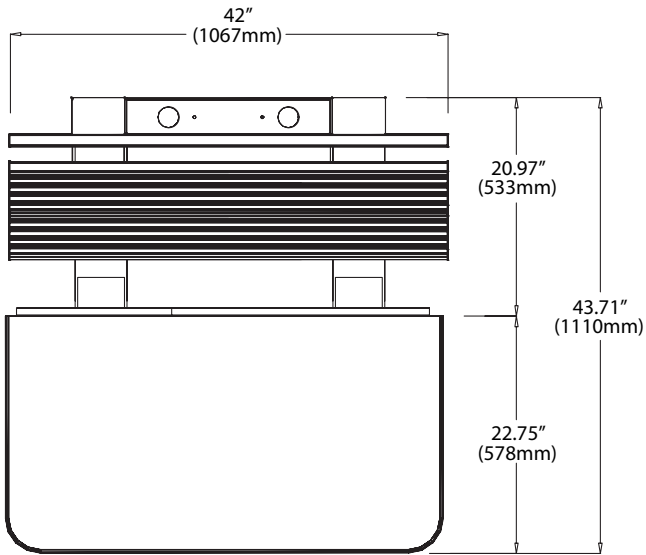

60" CHASE W/FRAMES

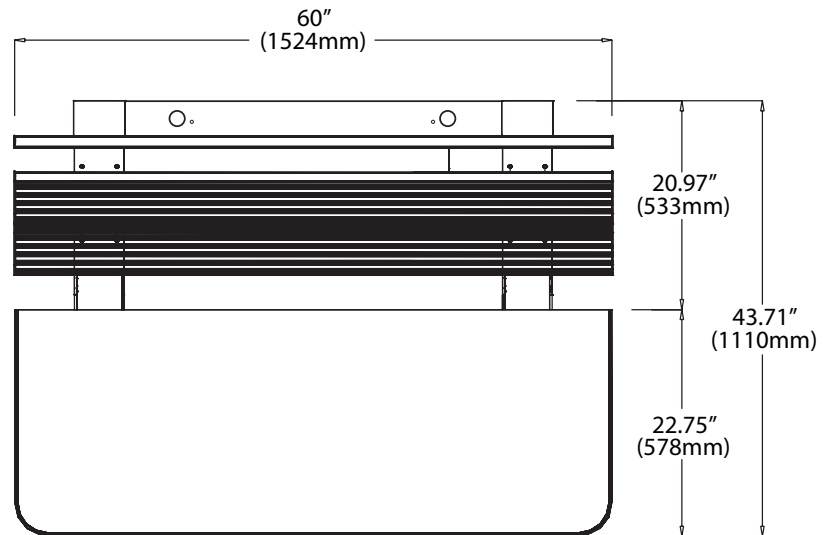

84" CHASE W/FRAMES

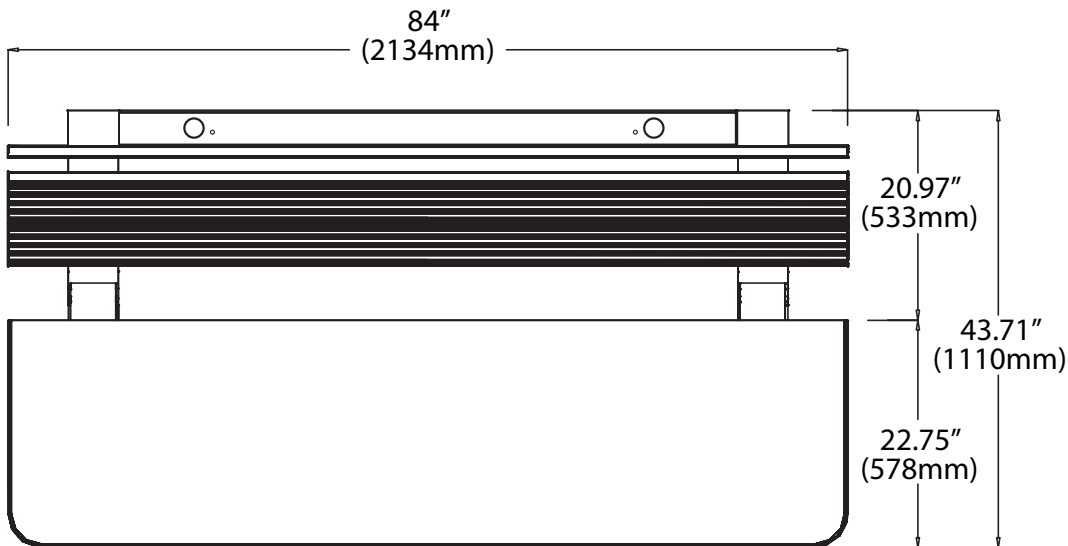

APPENDIX B

ERGONOMIC DETAIL

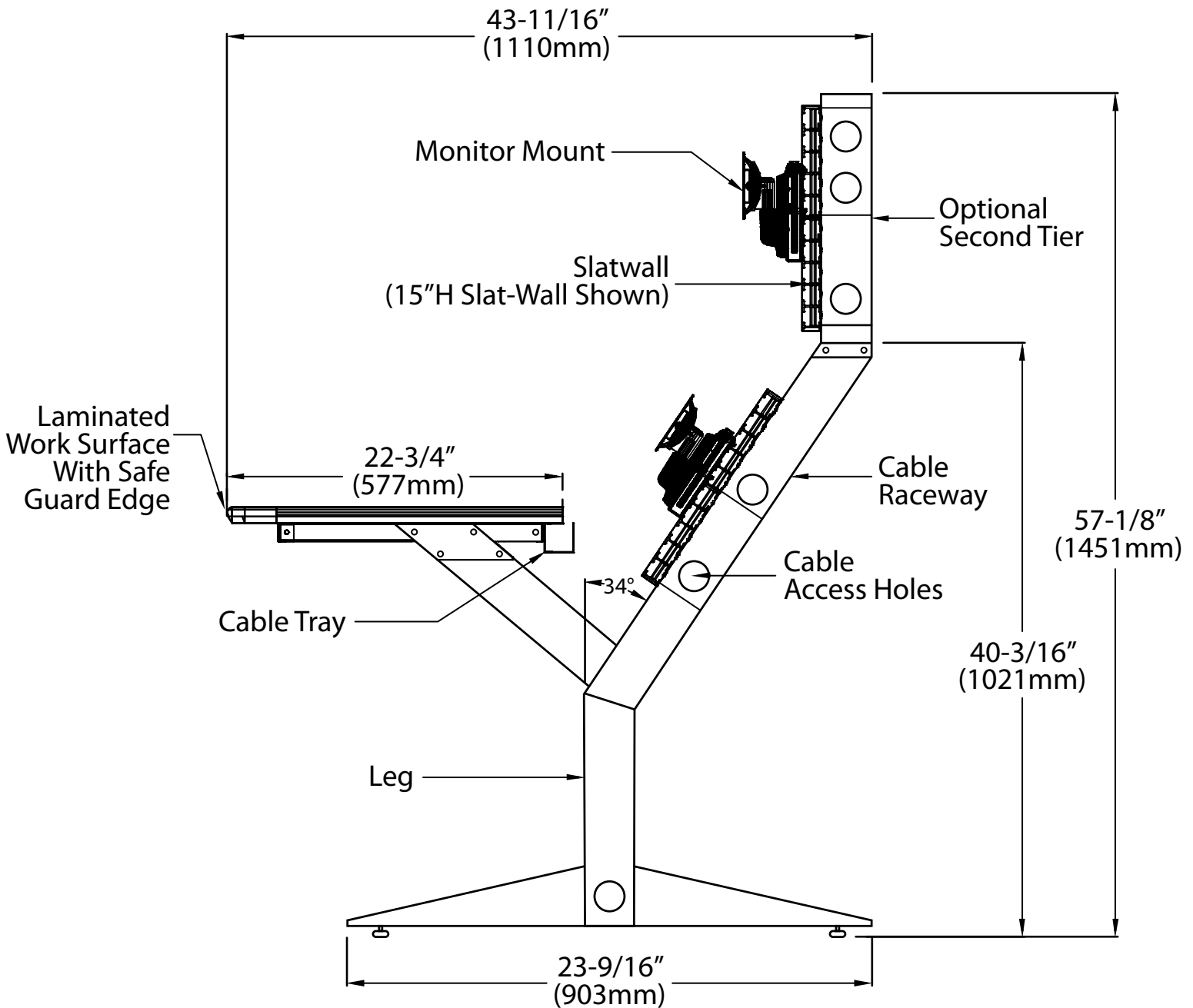

APPENDIX C

ERGONOMIC DETAIL

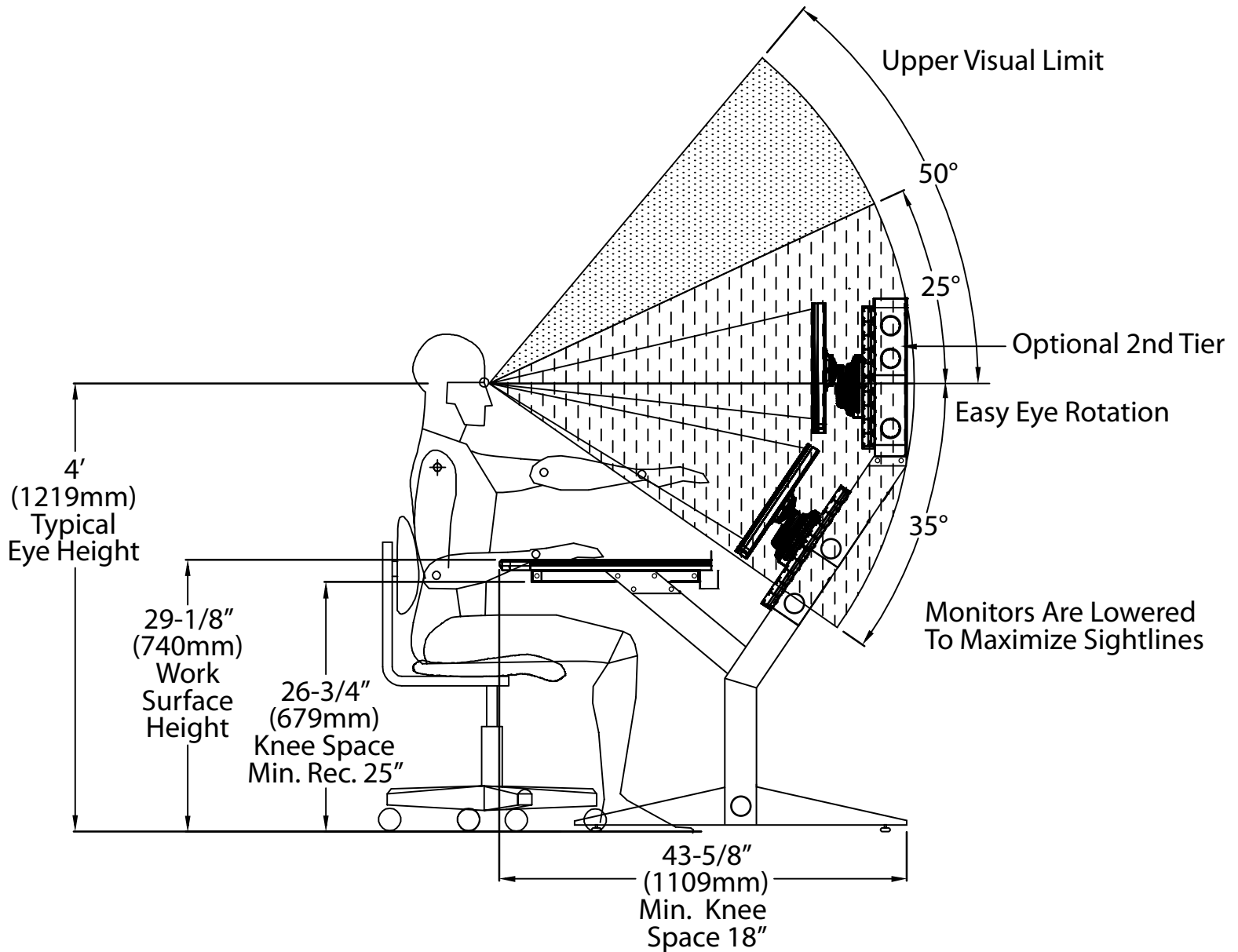

APPENDIX D